

**Flusher disinfectors**  
for hospitals and nursing houses



**Steelco**  
devoted to hygiene



# Flusher disinfectors for hospitals and nursing houses

Steelco continues to increase its international reputation through its strategy of investment in product development. This range of **Flusher Disinfectors** offers to the customers a large choice of machines with consistently tested and efficient washing performance. The Steelco range of **flusher disinfectors** has guaranteed for many years unrivalled hygiene and cleaning standards, it handles and disinfects all reusable items such as bedpans, urine bottles and buckets. With Steelco, both the patients and the nursing staff are assured to be hygienically secure!



> BP 100 HSER series  
free standing - compact

> BP 100 HE series  
free standing  
or wall installation

Hygiene within hospitals, nursing homes, geriatric wards, rehabilitation centres:

Automatic washer  
disinfectors



FLY CUTTER  
drainage bags thermal disinfectors





“For the Environmentally conscious”

Constant improvements and innovations lead **Steelco** products to run economically and reach a higher level of environment compatibility.

## Infection control

Thermal disinfection is the recommended and most efficient method for the disinfection of all reusable items such as bedpans, urine bottles suction bottles and buckets. Flusher disinfectors are a fundamental aid for the control of hospital infections and can significantly improve staff work conditions.



> BP 100 series  
underbench installation

> BP 100 H series  
large capacity single door

> BP 100 HL2 series  
double door pass through

> BP 100 HLA  
full glass sliding up door

## Standard compliant

Steelco Flusher Disinfectors are designed and constructed to comply with the latest European and UK guidelines on decontamination EN ISO 15883-1/3.

Steelco Flusher Disinfectors are classified CE Medical Device (Community rule 93/42/CEE).





single jet rotating nozzles

multiple jet washing arm

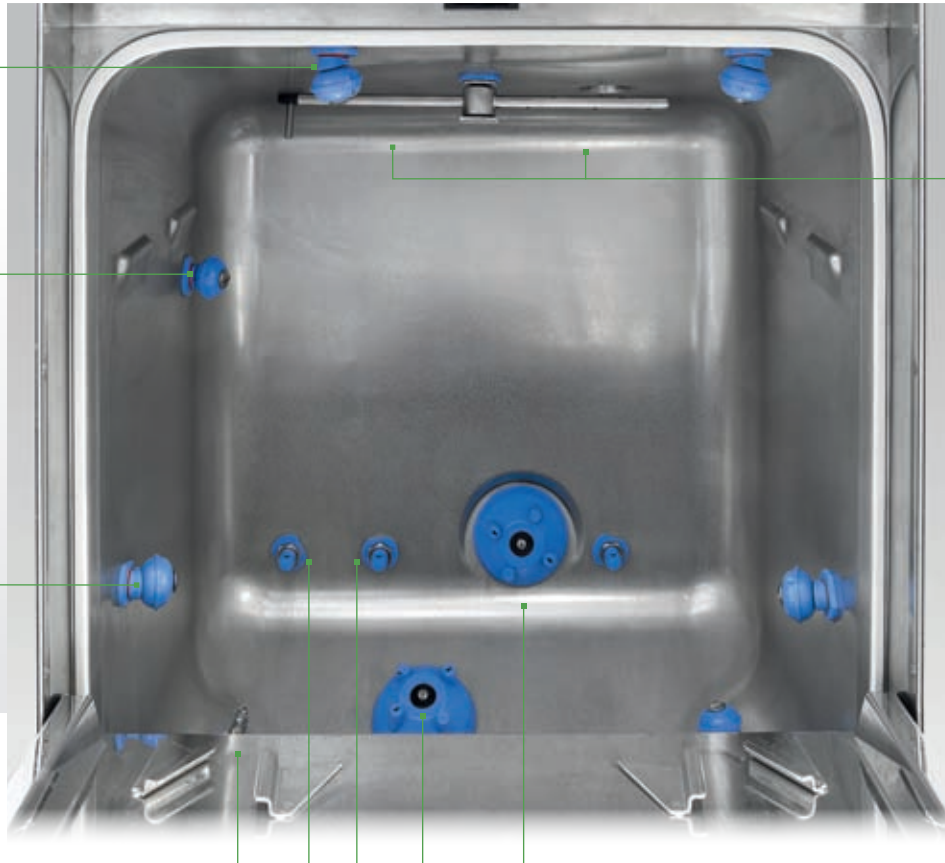

**BP 100 HE series**  
washing chamber

single jet fix nozzles

four jet rotating nozzles

## A self disinfecting device

Efficient tested cleaning results achieved thanks to many fixed and rotating nozzles which provide optimum water distribution inside and outside the treated items. External and inner cabinet made of stainless steel AISI 304. To eliminate the risk of accumulation of dirt and bacteria growth, the internal part of the chamber is manufactured with rounded corners and the interior side of the door with smooth edges.

Steam is distributed inside the chamber through the washing circuits and nozzles to assure at every cycle a perfect disinfection of the treated items, of the chamber and of the hydraulic circuits.

## Drying and cooling of treated items

Every Steelco bedpan washer disinfectant model can be equipped with the high efficiency drying/cooling fan system.

An option that allows all receptacles to be rapidly dried and cooled down. To do it in the most hygienic way, the air can be HEPA filtered (H14).

With this option the staff safety is improved when unloading the treated items at the end of the cycle and they can be immediately reused.

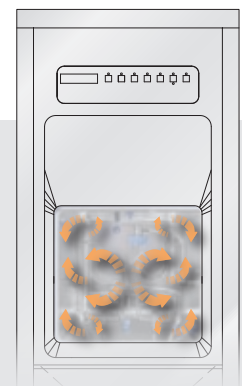

## Steelcotronic Control System

Steelcotronic Control System, with auto-diagnostic checking that constantly monitors and displays current cycle status and alarms, allows to optimize the washing process and to personalize programs on board of the machine. Three washing and disinfection programs are factory set:

- **short** - for bedpans and urine bottles containing liquids only
  - **standard** - for bedpans or buckets containing solid residues
  - **intensive** - for suction bottles and whenever in blood presence
- three more programs are available to be set by the operator.



Steelco bedpan washers are equipped with a 3 digit LED or 32 digit LCD display control panel that shows, at every moment of the ongoing treatment, the indication of the treatment program, the working phase, the chamber temperature,  $A_0$  value during disinfection phase until the reach of the cycle completion.

On the LED control panel, indications are displayed by abbreviations, on the LCD one, the status, alarms and descriptions are extended.



## Automatic door opening

All Steelco bedpan washer disinfectors can be equipped with automations to guarantee the nursing staff to be hygienically secure.

Door opening and closing can be controlled by pedals or by an infrared sensor that totally avoids operator-machine physical contact.

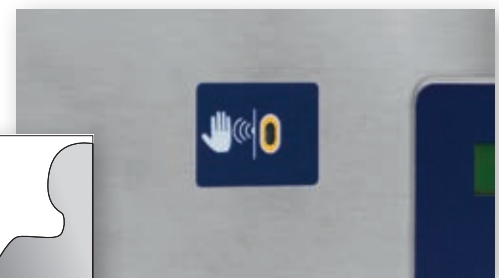

## Safety first

Door chamber is locked during the whole cycle, door opening is possible only once disinfection is complete.



## Safe chemical storage

Chemical tanks can be stored inside the lockable cabinet on the machine basement.

For the wall mounted versions the lockable chemical storage is placed on the upper part of the machine.

The underbench models can be equipped with dedicated side cabinets.





## BP 100 HE series

the range of wall installation and free standing models

The Steelco range of **compact flusher disinfectors** has guaranteed for many years unrivalled hygiene and cleaning standards, it handles and disinfects all reusable items such as bedpans, urine bottles and buckets. With Steelco, both the patients and the nursing staff are assured to be hygienically secure!



55  
cm  
21.65"



45  
cm  
17.72"

### BP 100 HE

wall installation models

- Manual door opening and closing
- Fully automatic door

### BP 100 HE

free standing models

- Manual door opening and closing
- Automatic door opening  
Manual door closing
- Fully automatic door

### BP 100 HSER

free standing compact models

- Manual door opening and closing
- Fully automatic door

### Capacity



Simultaneous treatment of 1 urine bottle and 1 bedpan with lid or up to 3 urine bottles.

Capacity depends on the size and shapes of the items that have to be treated. Combinations of bottles and bedpans are possible, capacity may vary.

### Capacity



Simultaneous treatment of 1 urine bottle and 1 bedpan with lid or up to 2 urine bottles.

Capacity depends on the size and shapes of the items that have to be treated. Combinations of bottles and bedpans are possible, capacity may vary.

## BP 100 HE series - General key features

- A multi-functional aid capable of holding all the receptacles commonly used in hospitals and nursing houses.
- Steelcronic control system, with auto-diagnostic checking that constantly monitors and displays current cycle status and alarms, allows to optimize the washing process and to personalize programs on board of the machines.
- LED display control panel.
- Steam is conveyed through the washing nozzles to ensure the complete disinfection of the washing circuit during each process.
- Lime-scale remover pump as standard, detergent pump is optional.
- Efficient tested cleaning results achieved thanks to many fixed and rotating nozzles which provide optimum water distribution inside and outside the treated items.
- Soiled goods are loaded at an ergonomic working height.
- Steelco flusher disinfectors are available with automatic door opening by a foot-operated pedal or with an optional infra-red proximity switch.
- The washer is equipped with a universal holder. Different racks and holders are available for special needs.

### Optional

- Detergent dosing pump
- Door opening controlled by infra-red proximity switch
- LCD display control panel
- Drying/cooling fan system
- HEPA H14 filter for drying/cooling fan system
- Wall installation version
- Connection for external steam supply

BP 100 HE load examples



BP 100 HSER load examples



Foot operated automatic door



## BP 100 - Underbench bedpan washer disinfectors

Steelco under counter flusher disinfecter models are made to hygienically handle and disinfect all reusable items such as bedpans, urine bottles, suction bottles and buckets.

To eliminate the risk of accumulation of dirt and bacteria growth, the internal part of the chamber is manufactured with rounded corners and the interior side of the door with smooth edges.



**60**  
cm  
**23.62"**

### BP 100

underbench models

- Manual door opening and closing
- Fully automatic door

### Capacity



Simultaneous treatment of 1 urine bottle and 1 bedpan with lid or up to 4 urine bottles.

Capacity depends on the size and shapes of the items that have to be treated. Combinations of bottles and bedpans are possible, capacity may vary.



**90**  
cm  
**35.43"**

**140**  
cm  
**55.12"**

BP 100 underbench bedpan washers can be integrated into counters with hinged door side compartment for easy storage of chemicals and/or accessories.

#### Counter with lateral cabinet

**L90** mm. 900x600x885h  
35.43"x23.62"x34.84"h

#### Counter with lateral cabinet and sink

**L90S** mm. 900x600x885h  
35.43"x23.62"x34.84"h  
Sink mm. 230/9.06 wide

Emptiers are available in manual or automatic version providing automatic drain and water sink rinsing.

#### Emptiers

**L50E** can be equipped with a faucet  
mm. 500 x 700 x 900h  
19.68" x 27.56" x 35.43"h

**L50** ideal with wall mounted faucet  
mm. 500 x 600 x 900h  
19.68" x 23.62" x 35.43"h



## BP 100 - General key features

- A multi-functional aid capable of holding all the receptacles commonly used in hospitals and nursing houses.
- Steelcronic control system, with auto-diagnostic checking that constantly monitors and displays current cycle status and alarms, allows to optimize the washing process and to personalize programs on board of the machines.
- LCD display control panel.
- Steam is conveyed through the washing nozzles to ensure the complete disinfection of the washing circuit during each process.
- Lime-scale remover pump as standard, detergent pump is optional.
- Efficient tested cleaning results achieved thanks to many fixed and rotating nozzles which provide optimum water distribution inside and outside the treated items.
- Soiled goods are loaded at an ergonomic working height.
- BP 100 models are available with automatic door opening by a foot-operated pedal or with an optional infra-red proximity switch.
- The washer is equipped with a universal holder. Different racks and holders are available for special needs.

### Optional

- Detergent dosing pump
- Door opening controlled by infra-red proximity switch



Example of the most commonly accepted bed pans and urine bottles.

BP 100 washing chamber



110  
cm  
43.30"



# BP 100 H series - Large capacity and pass through bedpan washers

Steelco **large capacity BP 100 H series models** are made to hygienically handle and disinfect all reusable items such as bedpans, urine bottles, suction bottles and buckets. **BP 100 HL2 models** are **pass through bedpan washers** mainly dedicated to be used in infected areas to avoid cross contamination.



55 cm  
21.65"



60 cm  
23.62"

## BP 100 H series single door models only

- Manual doors opening and closing
- Automatic loading door opening/manual closing
- Automatic door

## BP 100 HL2 series pass through models only

- Manual doors opening and closing
- Automatic loading door opening, manual unloading door

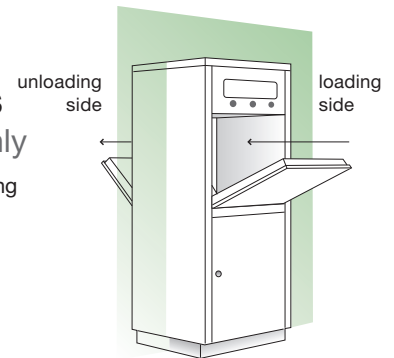

### Capacity



Simultaneous treatment of 2 urine bottles and 1 bedpan with lid or up to 4 urine bottles.

Capacity depends on the size and shapes of the items that have to be treated. Combinations of bottles and bedpans are possible, capacity may vary.

### Capacity



Simultaneous treatment of 2 urine bottle and 2 bedpans with lid, or up to 4 urine bottles.

Capacity depends on the size and shapes of the items that have to be treated. Combinations of bottles and bedpans are possible, capacity may vary.

## BP 100 H series - General key features

- Steelco control panel with LCD display is easy to use and simple to understand.
- Steelcotronic control system, with auto-diagnostic checking that constantly monitors and displays current cycle status and alarms, allows to optimize the washing process and to personalize programs on board of the machines.
- Efficient tested cleaning results achieved thanks to many fixed and rotating nozzles which provide optimum water distribution inside and outside the treated items.
- Lime-scale remover pump is a standard equipment, detergent pump is optional.
- Steam is conveyed through the washing nozzles to ensure the complete disinfection of the washing circuit during each process.
- Soiled goods are loaded at an ergonomic working height.
- Steelco Flusher Disinfectors are available with automatic door opening by a foot-operated pedal or with an optional infra-red proximity switch.
- The washer is equipped with a universal holder. Different racks and holders are available for special needs.

### Optional

- Detergent dosing pump
- Door opening controlled by infra-red proximity switch
- Connection for external steam supply
- Drying/cooling fan system
- HEPA H14 filter for drying/cooling fan system

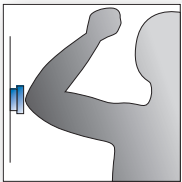

Standard with LCD display and **hygienic safe cycle selection and start** through elbow contact.



BP 100 H load examples



Emptiers are available in manual or automatic version providing automatic drain and water sink rinsing.

#### Emptiers

**L50E** can be equipped with a faucet with lever handle  
mm. 500 x 700 x 900h - 19.68" x 27.56" x 35.43"h

**L50** ideal with wall mounted faucet  
mm. 500 x 600 x 900h - 19.68" x 23.62" x 35.43"h



## BP 100 HLA high visibility full HST glass sliding-up door



This bed pan washer disinfectant, with full HST glass sliding-up door, automatically reprocesses any kind of urine bottles, bed pans and suction bottles.

The characteristics of this bed pan washer **improve the working condition, optimize the cleaning results and reduce drastically the risk of contamination.**

An infra-red proximity switch or a foot pedal facilitates the operator to open and close the sliding door automatically **avoiding any physical contact of the staff.**

### Rotating holder



The holder/support rotates automatically to empty items only after the door is completely closed and then the machine starts the washing cycle.

### Multifunction support

The multifunction holder/support allows combined simultaneous treatment of urine bottles, bed pans, suction bottles and buckets.

A wide range of supports is available following the containers which are most commonly used in the different countries.

### Capacity



Simultaneous treatment of 2 urine bottles and 1 bedpan with lid or other combinations with suction bottles or buckets.

Capacity depends on the size and shapes of the items that have to be treated. Combinations of bottles and bedpans are possible, capacity may vary.



## BP 100 HLA - General key features

- Automatic motorized vertical sliding door made of HST (high shock tested) tempered glass with safety device.
  - Soiled goods are loaded at an ergonomic working height.
  - Steelco control panel is safe to use and simple to understand. Process phases can be monitored in real time both visually by the full glass door or through control panel display. Cycle phases are: emptying, washing and steam thermodisinfection.
  - Efficient tested cleaning results achieved thanks to many fixed and rotating nozzles which provide optimum water distribution inside and outside the treated items.
  - Steam is conveyed through the washing nozzles to ensure the complete disinfection of the washing circuit during each process.
  - Steelcotronic control system, with auto-diagnostic checking. A safe and easy to operate control panel, with 32 characters LCD display, constantly monitors and displays current cycle status and alarms. The control panel allows to optimise the washing process and to personalize programs on board of the machines.
- Automatic door opening by a foot-operated pedal or with an optional infra-red proximity switch.
  - Lime-scale remover pump as standard, detergent pump is optional.
  - Detergent and lime-scale agent tanks are placed under the chamber in a safe and locked position.

### Optional

- Detergent dosing pump
- Door opening controlled by infra-red proximity switch
- USB port for cycle data downloading
- Drying/cooling fan system
- HEPA H14 filter for drying/cooling fan system
- Connection for external steam supply





## Accessories: item holders

The washer is equipped with a universal holder. This multifunction holder/support allows combined simultaneous treatment of urine bottles, bed pans, suction bottles and buckets. A wide range of supports is available following the containers which are most commonly used in the different countries. Different racks and holders are available for special needs.

**Removable rack on slides.**  
With this accessory, the washer can be also used for washing and disinfecting small objects.



**Removable shelf** to be positioned on the bottom of the washing chamber to allow easy washing and disinfection of big size buckets and basins.



Special rotating holder is dedicated to make item loading even easier.



## Complements

Steelco can provide a complete range of accessories as counters with/without sinks, emptiers and wall racks for bedpans and urine bottles.

# Technical information

**BP 100 HE**

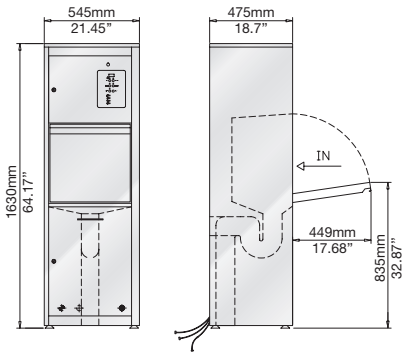

**BP 100 HE wall installation**

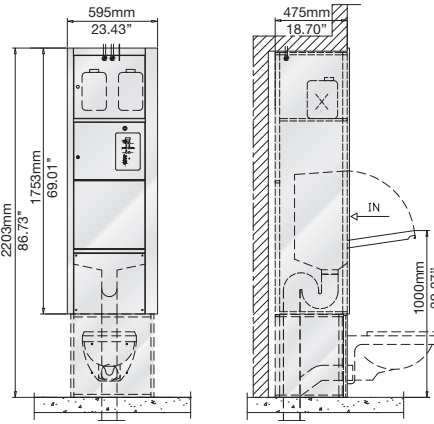

**BP 100 HSER**

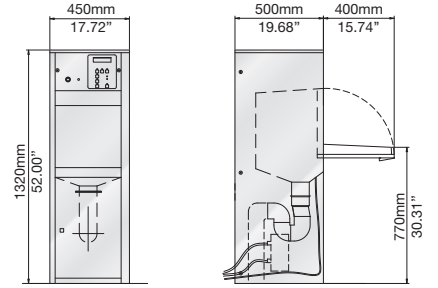

**BP 100**

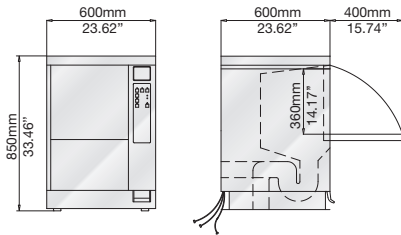

**BP 100 H**

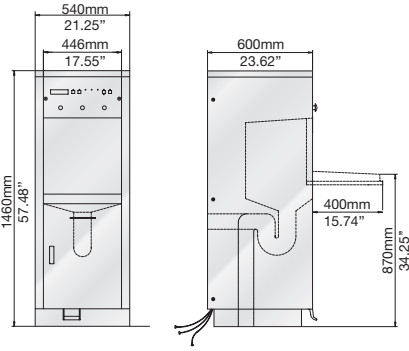

**BP 100 HLA**

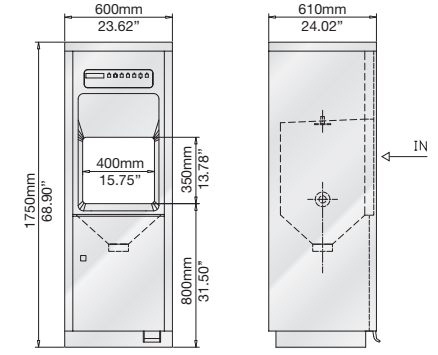

Bedpan and urine bottle wall racks

**BP 100 HL2**

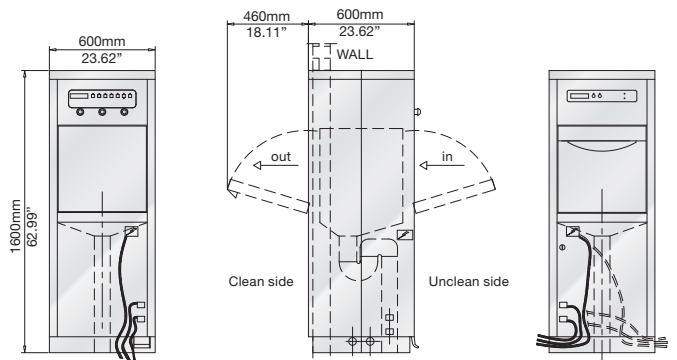



[www.steelcospa.com](http://www.steelcospa.com)



Headquarters

**STEELCO S.p.A.**

Via Balegante, 27 - 31039 Riese Pio X (TV) - Italy  
 Ph. +39 0423 7561 - Fax +39 0423 755528  
 e-mail: [steelco@steelcospa.com](mailto:steelco@steelcospa.com)  
[www.steelcospa.com](http://www.steelcospa.com)

Branches

**STEELCO HUNGARY**

Temesvár u., 19-21  
 1116 Budapest - Hungary  
 Ph. +36 1 371 0257  
 Fax +36 1 371 0258  
 e-mail: [steelco@t-online.hu](mailto:steelco@t-online.hu)

**STEELCO USA**

999 Stinson Way - Unit 307  
 West Palm Beach, FL 33411 USA  
 Ph. +1 561 791 8313  
 Fax +1 561 791 8213  
 e-mail: [contact@steelco-usa.com](mailto:contact@steelco-usa.com)

**STEELCO ASIA**

6th floor, Suite 16, IOI Business Park  
 Persiaran Puchong Jaya Selatan - Bandar Puchong Jaya  
 47100 Puchong, Selangor - Malaysia  
 Ph +60 3 8064 4339 (Ext. 112) - Fax: +60 3 8064 4340  
 e-mail: [adminasia@steelcospa.com](mailto:adminasia@steelcospa.com)



Products offered for sale may differ from those described or illustrated in this brochure due to later production changes or/and optional configurations. The products and technical specifications are subjected to change without prior notice. Please consult your Steelco dealer for the latest information.