

Washer disinfectors

CSSD Range - Systems and Automations



Steelco
your partner in infection control



“For the Environmentally conscious”



Washer disinfectors

CSSD Range - Systems and Automations

Properly designed central of sterilization departments facilitate the one-way flow of instruments between soiled and clean work areas and sterile storage. Walls and other barriers are separating the functional areas of a CSSD.

The challenge for architects, planners, hospital and department managers is to elaborate the ideal configuration of equipment, available space and layout. Thereby all requirements on throughput, capacity, logistics, ergonomics, serviceability, infection prevention and control must be considered.

Steelco is the solution provider in the field of the automated washing and disinfection. Our product line for CSSDs offers the largest assortment of instrument reprocessors and automation systems which is the answer to the customers' needs.

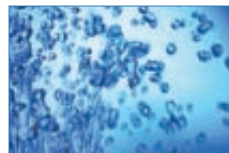

Our systems and automations are designed to fulfil all customer expectations such as increasing staff productivity, saving time, water and energy consumption thus helping to create the basis for a long lasting satisfying experience.

Standard compliant

Steelco Washer-Disinfectors are designed and constructed to comply with the latest European and UK guidelines on decontamination. EN ISO 15883-1/2, CEN ISO/TS 15883-5.
Steelco Washer-Disinfectors are classified CE Medical Device (Community rule 93/42/CEE) code nr. 0051.





“For the Environmentally conscious”

Constant improvements and innovations lead **Steelco** products to run economically and reach a higher level of environment compatibility.



Steelco can provide a full system planning Service to support CSSD team Managers in customizing lay-out configuration for new or restructured projects.



Washer disinfectors

CSSD Range - Systems and Automations

Flexibility for any installation layout

The large product range allows us to find the ideal line up of washer disinfectors for any installation layout.

Our aim is to offer multiple concepts for each project in order to provide customers with more than one solution among which to choose to satisfy their specific needs.

Productivity range

The individual need for instrument throughput is considered by our customized capacity concepts, which offer valuable and future-proof solutions for your CSSD project.

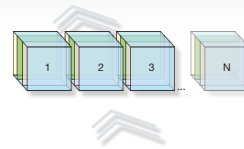

- > DS 800
- > DS 800 2S



12 DIN 1/1 trays
washer disinfectors

- > DS 1000
- > DS 1000 3S



18 DIN 1/1 trays
washer disinfectors

Other medical range
Steelco products:

Washer disinfectors
for transfer trolleys, sterile containers





“For the Environmentally conscious”



Fast Cycle washer disinfectors

Steelco CSSD washer disinfectors combining the energy saving concept with the highest standard cleaning and drying performance in a very short cycle time.

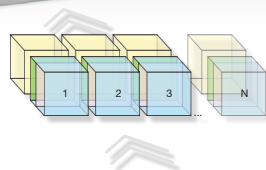

> TW 3000/2 smart tunnel

18 DIN 1/1 trays
double chamber compartment
washer disinfectant

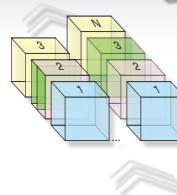

> TW 3000/3 /4 /5

18 DIN 1/1 trays
multi chamber compartment
washer disinfectant

Steam sterilizing autoclaves
CSSD range



ARES
Endoscope Reprocessing System



Washer disinfectors
Small/Medium Range





ATS Automatic Transfer System

ATS is an automation specifically designed for the processing departments where time is critical. A shuttle loader moves along the front of the soiled side of the washer disinfectors and loads the racks automatically into the first available washer.

Once the items have gone through the washing cycle, another ATS unloads the treated racks along the clean side and transfers them to a storage station ready for inspection and packaging. The relevant washing program is controlled by a processor according to the individual rack specifications.

Managing the restricted space challenge

Steelco offers the most innovative automation solutions for the washing and disinfection areas of a CSSD.

Steelco's automatic devices, such as the motorized rotating table and the ATS shuttle allow compact footprint layouts respecting accessibility and maintenance spaces. The highest level of flexibility is reached with the new rotating ATS shuttle. The experience in the transfer and storing table dimensioning elevates the value of Steelco solutions.



ATS benefits

- Equal distribution of thermal disinfectors workloads and consequent predictability and planning of maintenance costs.
- The washing systems can be located in narrow areas that are not normally accessible with manual loading.
- Easy cleaning of the area below the ATS system.

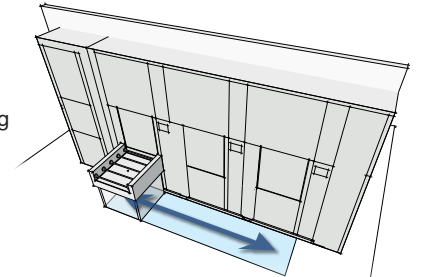

Device combination to upgrade productivity

Separating Cold and Hot washing cycle phasis

In terms of process efficiency, it is particularly convenient to designate one unit to the specific cold pre-wash phase.

Besides reducing process total time, it is possible to realize important energy savings because it avoids cold water loading in the washing chambers of the machines involved in the washing, thermal-disinfection and drying phases.

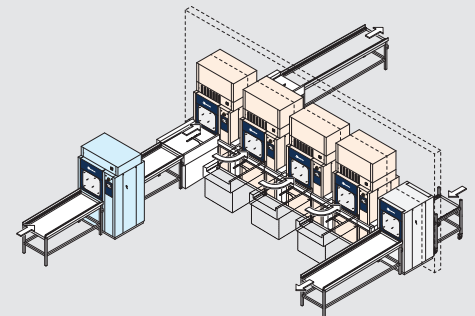

Solutions for any specific layout

Limited Spatial Depth

Due to our automated loading and unloading system ATS with rotating function, we are able to place our washer disinfectors close to walls and barriers.

In this way the total depth of the line up is significantly reduced compared to a manual/standard loading/unloading through the use of a transport trolley.

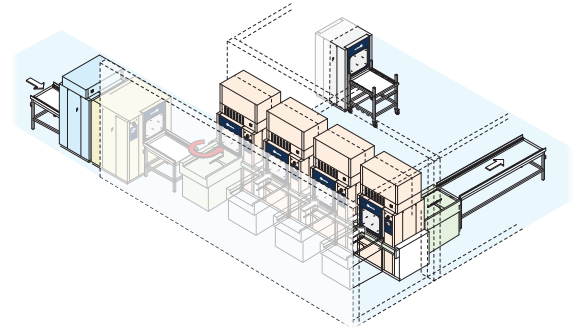

Limited width of the room

When planning a new CSSD department, sufficient width of the room is essential to place the required number of devices for throughput according to each individual need. Steelco TW-3000/2 Smart Tunnel provides over 75% increase of productivity without the need of a larger lateral floor space than the one of a conventional single chamber washer. By providing a higher throughput, the number of required devices is significantly reduced so that additional space is gained and investment costs can be lowered.

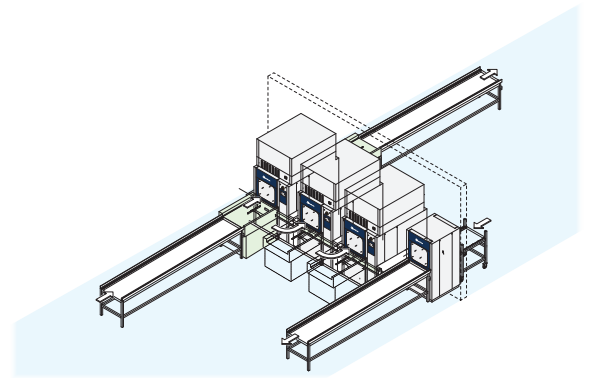

Long narrow room

Only the technology of a tunnel washer disinfectors can fulfill the requirements of a high instrument throughput in a narrow layout. Instead of a broad line up of single chamber devices, the construction of consecutively installed chambers of our TW-3000 series provides highest productivity in a limited space. The tunnel can be upgraded with an additional module for even higher throughput or for the use of integrated ultrasonic technology. Additional space can be gained by a set up with a central service area in between two devices.

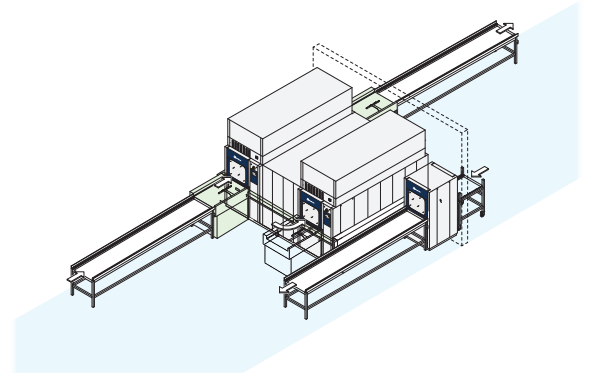

Reducing manual pre processing operations

According to internal procedures, ultrasonic cleaning unit can be used as an alternative support to the manual cleaning to remove biological debris in the most intricate shapes and cavities before the washing/disinfection process. Steelco ultrasonic treatment device US 1000 is designed for full integration in automated CSSD solutions.

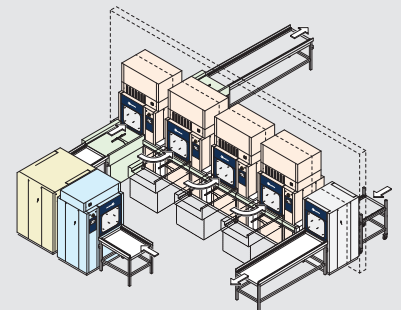



Traceability and device monitoring

An important element in the complex environment of a CSSD department is traceability. A computerized documentation system assures the connection of all automated devices, which are involved in the instrument reprocessing cycle. Additionally the principal validated parameters are monitored and the data storage of the batch documentation on the connected machinery is guaranteed.

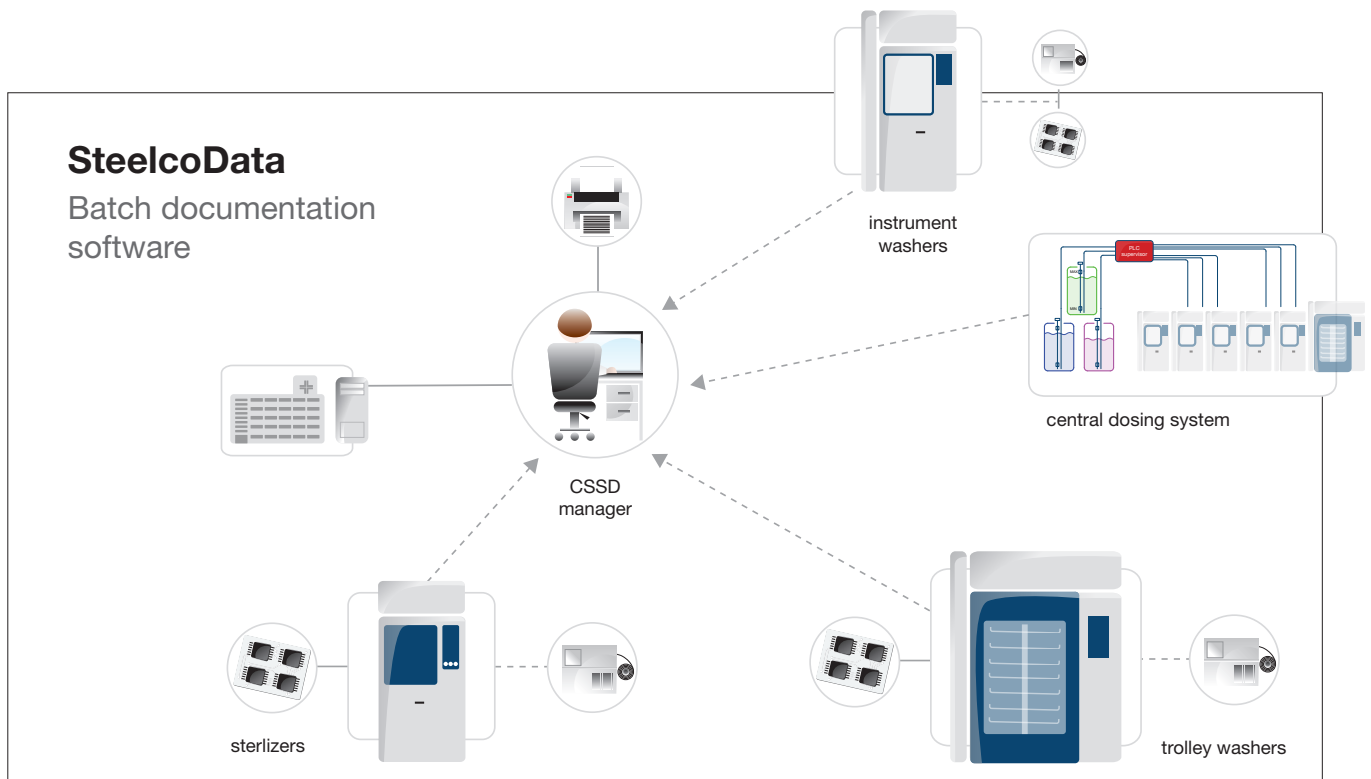

Our SteelcoData software package is used as a central platform for the batch data management of all connected devices. A file archive in the hospital network will be set up where any relevant process data is stored.

SteelcoData is encrypting the data arriving directly from the interfaces of all connected devices and is generating one document in a non editable format for the entire process.

Our software uses the data archive for creating individual statistics of consumptions and alarms history. Also the current status of each device can be visualized for a remote monitoring of the CSSD machinery.

SteelcoData is your solution for the end to end batch documentation.

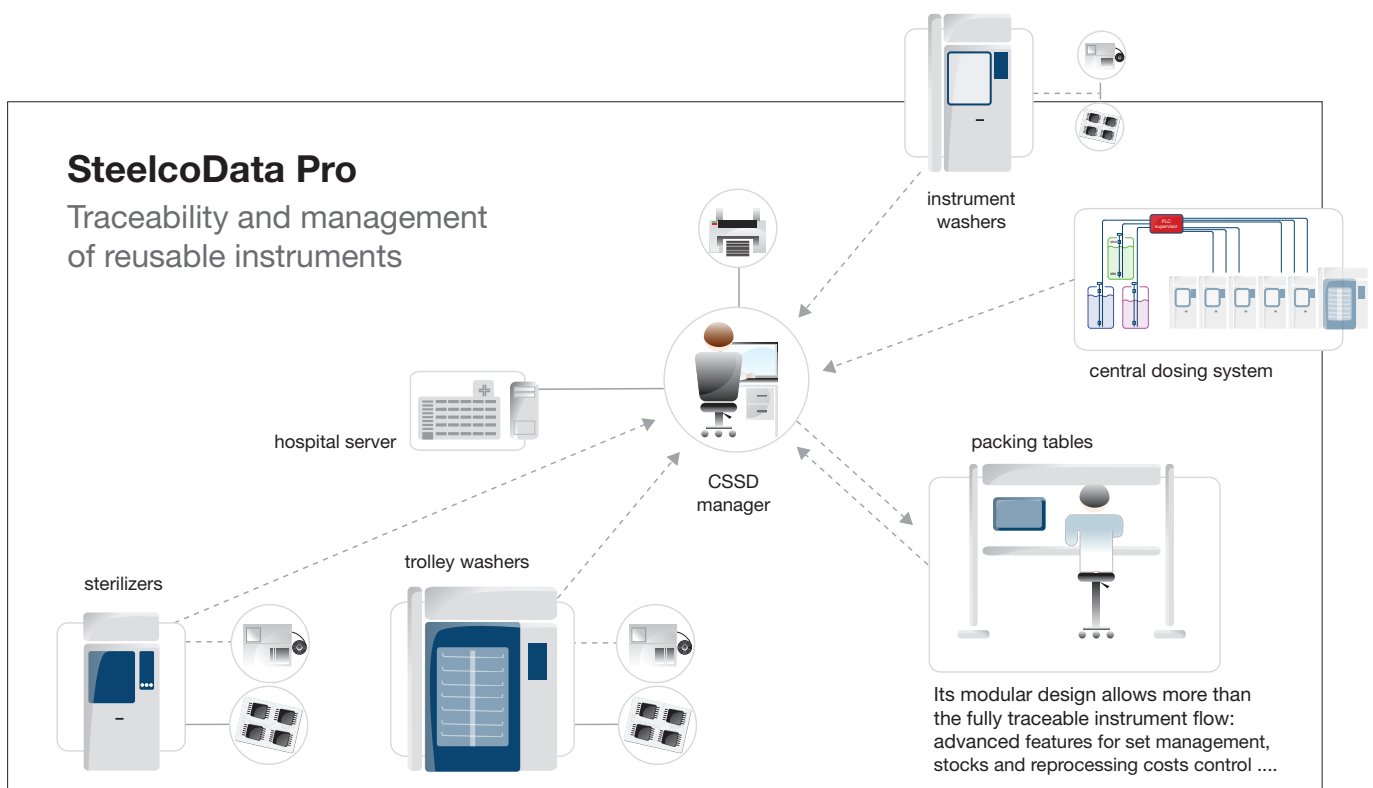

With SteelcoData Pro we are providing you the ERP solution for an easy management of your CSSD.

By Its modular structure we can set up a customized software tool based on your needs and financial capabilities.

SteelcoData Pro includes the complete documentation of your sterile supply, optimized and standard procedures, well-structured inventory management and legal conformity.

Hence full cost transparency of your entire instrument re processing is guaranteed.

SteelcoData Pro secures not only a cost efficient and fully traceable instrument flow, but also provides a user-friendly CSSD management tool for your daily needs.



The Fast Cycle concept



Steelco follows the growing Customer demand for washer disinfectors which can combine high standard cleaning and drying results with work efficiency and very short cycle time.
(DS 800 and DS 1000 Fast Cycle configuration machines)

Key features of the fast cycle machines:

Save time - big capacity pre-heating tanks directly connected through large valves, into the washing chamber, grant effective results in reducing cycle time.

Save water - the water recirculation tank grants the recycling of the disinfection water into the next washing cycle with the reduction of energy and water consumption.

Save energy - cycle time reduction and thermal insulation.

A fast cycle washer disinfector can save over 54.000 liters of water in an year of average use, it is worth!

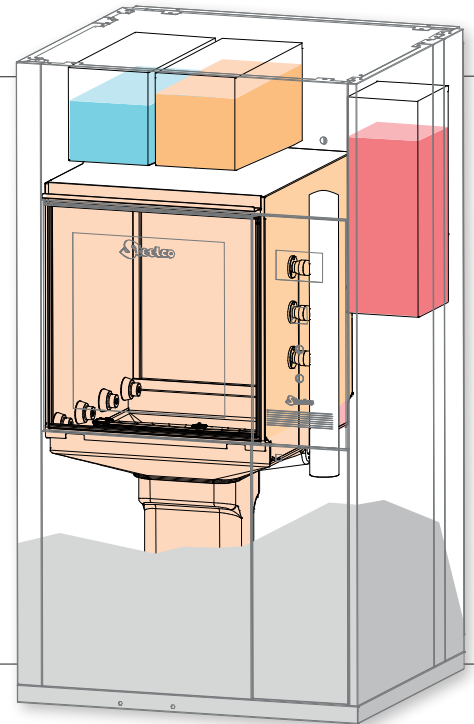

Fast cycle facts

Steelco fast cycle machines can be configured to perform a **complete and validated** instrument washing, disinfection and drying **cycle in only 30 minutes**.

water

-25%

energy

-40%

time

-50%



Focused on the environment care theme Steelco has greatly improved working efficiency with the reduction of energy consumption due to cycle time reduction, heat exchanging and thermal insulation.

1, 2, or 3 tank configurations applied to a 5 phases fast cycle

Steelco fast cycle machines tank configuration can vary in numbers, function and heating temperatures to best suit customer procedures.

The following table shows some examples of a 5 phase fast cycle configuration. Temperatures are referred to pre heating tanks, higher temperatures up to 93°C/199°F are then reached by sump heating.

- | | |
|---|------------------------------------|
| 1 | cold water pre-wash phase |
| 2 | warm water washing phase |
| 3 | warm water rinsing phase |
| 4 | DI water thermaldisinfection phase |
| 5 | forced hot air drying phase |

tanks	functional description
	<p>The pre heated 85 °C / 185 °F demineralized water tank allows to radically reduce thermaldisinfection process time and consequently total cycle time. Pre heated demineralized water flows directly with the shortest possible connection to the washing chamber without pump activity and minimizing heat loss.</p>
	<p>The pre heated 65 °C / 149 °F hot water washing tank allows the reduction of the washing process time and consequently of the total cycle time.</p> <p>The same tank is then used to pre heat the rinsing water while the machine is performing the washing phase. Saving heating time avoids washing chamber to cool down thus reducing energy loss.</p> <p>The pre heated 85 °C / 185 °F demineralized water tank allows to radically reduce thermaldisinfection process time and consequently total cycle time. Pre heated demineralized water flows directly with the shortest possible connection to the washing chamber without pump activity and minimizing heat loss.</p>
	<p>The needed amount of pre washing cold water flows from the first tank directly to the washing chamber rapidly and without any pump activity.</p> <p>The pre heated 65 °C / 149 °F hot water washing tank cuts down “in chamber” water heating time allowing the reduction of the washing process time and consequently of the total cycle time.</p> <p>The same tank is then used to pre heat the rinsing water while the machine is performing the washing phase. Saving heating time avoids washing chamber to cool down thus reducing energy loss.</p> <p>Following customer procedures, pre heated rinsing water can be recycled from the previous cycle thermaldisinfection water thus adding a significant energy, water and time saving.</p> <p>The pre heated 85 °C / 185 °F demineralized water tank allows the radical reduction of the thermal disinfection process time and consequently of the total cycle time. Pre heated demineralized water flows directly with the shortest possible connection to the washing chamber without pump activity and minimizing heat loss.</p>



Cleaning effectiveness

The **Mechanical** action is one of the main elements for the cleaning effectiveness of the washing process, Steelco has studied different washing pumps for the wash circuit of each individual model to ensure the highest water flow rate combined with an efficient spray pressure. According to internal procedures, ultrasonic cleaning units can be used as a support of the manual cleaning to remove biological debris in the most intricate shapes and cavities before the washing disinfection process.

Drying: a primary importance phase

Proper drying is a fundamental guideline requirement and the specific phase can affect up to 15% of total process cycle duration of a conventional washer disinfectant and up to 30% of a Fast Cycle washer disinfectant.

Steelco has designed an efficient hot air drying system that allows the total elimination of the remaining water, both inside and outside of the instruments. Blowers are electronically controlled to adjust their speed in order to get the proper drying results.

Turbo Drying

Steelco Turbo Drying system controls drying air inlet for a HEPA filtered hot air recirculation inside the washing chamber. This advanced feature allows the reduction of the drying times and, as a result, energy and HEPA filter consumption.



Ultrasonic cleaning

Ultrasonic cleaning acts on immersed surfaces thousands times a second to insure perfect cleanliness even on the most intricate shapes.

Ultrasonic cleaning is safe for the most delicate and highly finished objects since there are no abrasives or harsh chemicals used and does not create scratches which would create cleaning problems later.

Steelco ultrasonic cleaners are designed for full integration in automated CSSD solutions (US 1000) or as stand alone units (US 80, 100, 200 and 300 series).



Improvements and innovations

Constant improvements and innovations lead our products to run economically and reach a higher level of environment compatibility. The reduction of energy and water consumption has always been a major priority in the development of Steelco products as confirmed by the new Fast Cycle generation technology washer disinfectors.

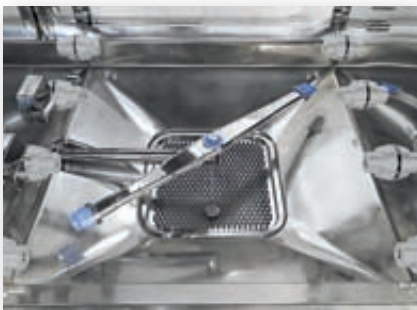

Washing chamber, washing arms, preheating tanks and triple stage water filtering system filters are made of high quality AISI 316L stainless steel (DIN 1.4404).

Washing chamber is designed and constructed with smooth edges and corners, removing areas where dirt can accumulate and allow bacterial growth.

Water sump level is checked by a volumetric system which allow the economising on cycle consumption.



Water coupling system distributes water to the racks washing arms and nozzles for efficient cleaning and uniform disinfection temperature coverage.

A low friction bearing eases chamber and cart washing arms rotation for an improved efficiency of the washing and drying phases. The spray arms are removable and the internal surface can be cleaned thanks to the easy access hinged caps put at the ends. Both operations can be done by hand and do not require any disassembling tool.



Thanks to the automatic cart recognition system all machine parameters and washing cycles are optimized, the end user job is really simplified and any risk of human error is drastically reduced.

Controls are available for continuous monitoring of washing, rinsing and thermal disinfection phases through pressure checking devices and washing arms rotation sensors.

Thermal disinfection

Thermal disinfection is the recommended and most efficient method for the disinfection of reusable medical devices. European guidelines strongly recommend thermal disinfection to be applied whenever it is possible. In order to satisfy all enquiries of laws regarding thermal disinfection in the different countries, thermal disinfection is achieved by gaining the temperature up to 93°C and with its holding for a programmable time, variable for each single cycle depending on different items to reprocess.

Thermal disinfection temperature is checked by means of 2 PT1000 independent probes.

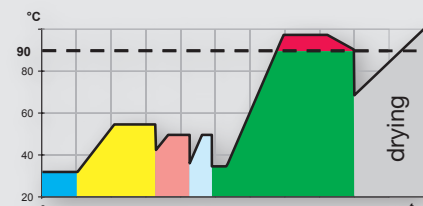



Trolleys, cart, baskets, inserts and accessories

The Steelco CSSD range offers customers a large choice of machines, loading trolleys, carts, baskets and inserts, all specifically designed to meet any end user needs.

Main applications are: Surgical instruments, MIS instruments, Anaesthesia instruments, Ophthalmology instruments, OP rubber shoes, Containers, Baby bottles...

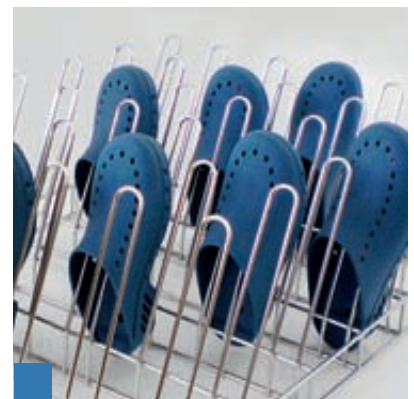

Control system

Steelcotronic Control System, with its auto-diagnostics, constantly monitors and displays the current cycle status and alarms. It allows the user to optimise the washing process and to personalize programmes on board.

Finally it assures moreover, the traceability of the principal validated parameters as requested from the European rules regarding the processing of reusable items.

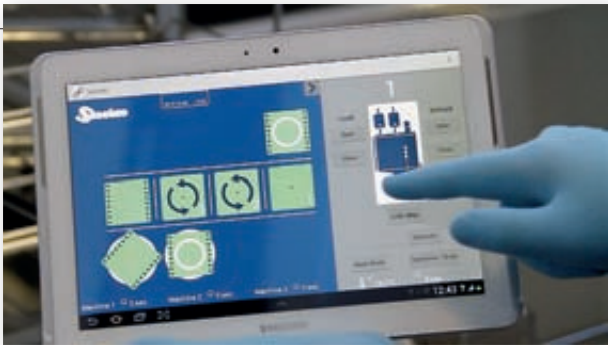

STEELCOTRONIC microprocessor control systems are available in several versions to best suit the customer needs. Different size control panel display interfaces are dedicated to the programming and the monitoring of a single stand alone machine up to more complex systems.

Control panels allow up to 100 memorized washing and disinfection programmes. A set of standard programs is available for Surgical instruments, MIS instruments, Anaesthesia

instruments, Ophthalmology instruments, OP rubber shoes, Containers, Baby bottles...

Control panel access is protected by 3 password levels for the installer, maintenance technician and end user.

Operator identification is requested to enable the washing cycle programming or their own start.

Print reports and historical cycle data

During every washing cycle the machine software generates a report that can be printed, stored or transferred to a hospital server connected via RS232 or ethernet port.

All critical parameters are registered, in particular:

- machine model and number, operator identity
- cycle starting/ending date and time, status at the end of the washing cycle
- executed A₀ values
- programmed and executed water and chemical consumption
- temperatures measured by 2 independent monitoring probes during each cycle phase





SteelcoChem Centralized Chemical Dispensing System

This system is designed for the automatic supply of chemicals to different washers placed in a CSSD department. SteelcoChem is the ideal solution to reduce the frequent manual loading of small containers into each washer disinfectant, thus saving time and money.

This solution improves the operators safety and avoids the risk of mixing chemical products. SteelcoChem is available as modular system that can be integrated with remote monitoring and further safety devices.

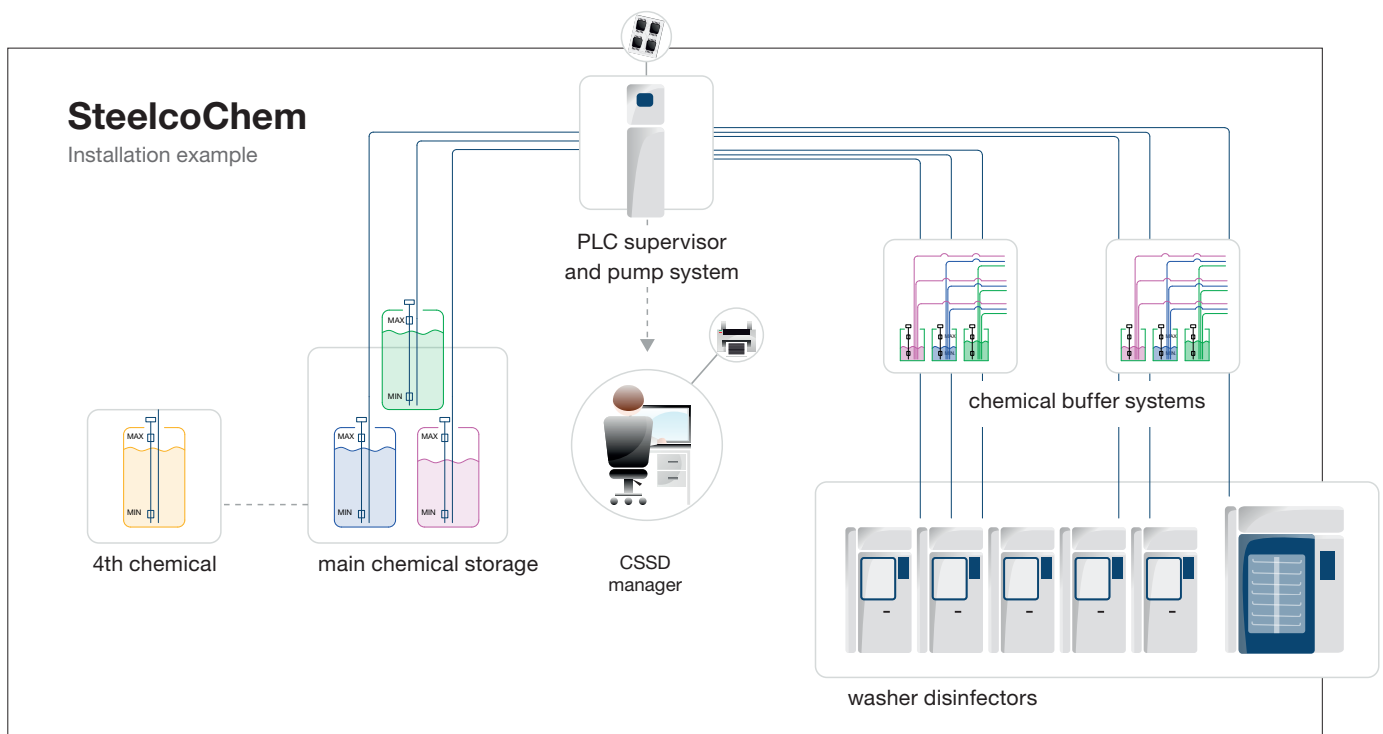

Main advantages of the system

- Cost reduction through the purchase of large quantities of chemical.
- No more need to replace small containers.
- Elimination of biological risk for operators.
- Avoidance of risk to exchange chemical products.
- The constant monitoring of consumptions and of remaining amount of chemical excludes the risk to interrupt the cycle due to lack of chemical.

*SteelcoChem gives your CSSD
the highest level of safety and uptime!*

Steelco CSSD - applied solutions





DS 750 - DS 800 - Washer disinfectors



Designed to meet the increasing reprocessing needs of CSSD, this washer disinfectant is available in standard or **Fast Cycle** configurations saving cycle time and reaching higher levels of energy and water savings.

The machines assure consistently tested and efficient washing-disinfecting performances thanks to a new washing system technology made by a vertical installed washing pump that grants also a complete drain of the washing circuit.

HEPA-filtered H14 forced air drying distribution on double circuit grants a perfect distribution of air on all chamber parts and basket levels ensuring the complete inside and outside drying of all the surgical instruments and tubes.

DS 800 models are compatible with **Steelco ATS** - Automatic Transfer System.

single door washer disinfectors

DS 750 Standard Cycle

DS 750 1S Fast Cycle

DS 750 2S

double door washer disinfectors

DS 800 Standard Cycle

DS 800 1S Fast Cycle

DS 800 2S

Washing chamber



Chamber vol. ~350 lt / ~92.46 Gal US
Wash cart vol. ~280 lt / ~73.97 Gal US

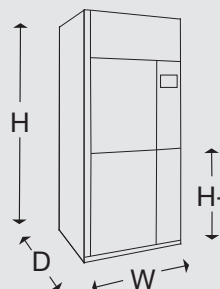

Washer dimensions

	W	D	H	H-	
DS 750* - DS 800*	mm	900	740	1940	850
	inches	35.43	29.13	76.38	33.46

*same dimensions for the Fast Cycle versions

DS 750 - DS 800 - Key features

- Steelcotronic control system supported by a color touch screen display.
- The ergonomic design of the door level height allows the user a convenient loading/unloading job with the support of a manual trolley or automatic loading/unloading conveyors.
- Door made of HST tempered glass.
- Inner cabinet, washing arms and tank filters made of high quality AISI 316L stainless steel.
- External cabinet made of AISI 304 stainless steel.
- Washing and DI disinfection temperature are fully adjustable up to 93°C/199°F.
- Temperature is monitored by two independent sensors.
- A powerful vertically installed washing pump that ensures high water flow rate combined with effective spray pressure and also grants a complete drain of the washing circuit.
- Washing/drying cart injection system.
- Electrical heated 26 kW total power (up to 38kW in Fast Cycle versions), 400V/3~+N/50Hz. Other electrical connections available as optional.
- Two standard automatic liquid dispensers provided with flow meter and level control.
- Possibility to store up to two 5 lt. (1.32 Gal US) containers into the basement.

Main optional features

- 3rd and 4th Chemical dosing pumps
- Steam or mixed heating
- Drain water heat exchanger
- Light inside of the chamber
- Conductivity sensor
- Steam condenser
- Drain cooling solenoid valve
- Integrated printer
- Analogic sensor on washing circuit for pressure check (registered data)
- Washing arm rotation sensors
- Bar code reader

Washing cart automatic identification.

Triple water filtering system captures residue preventing re-circulation.

Automatic motorized vertical sliding down doors with safety device.



Triple water connection for washing carts provided with spray arms and/or injection systems.

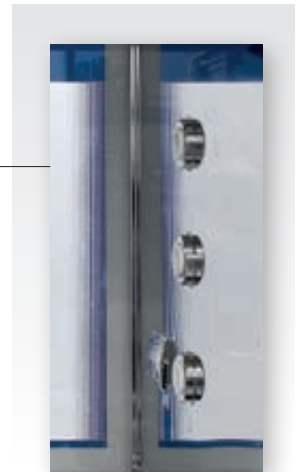

Fast Cycle versions

*total cycle time reduced up to **37 Minutes***

1S models are equipped with 1 big capacity pre-heating tank,
2S models with 2 big capacity pre-heating tanks.

Functions and heating temperatures of the pre heating tanks can be configured to best suit customer needs, allowing an effective results in reducing cycle time and water/energy recovery.

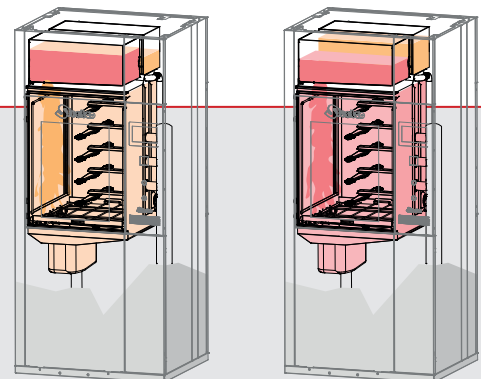



DS 900 - DS 1000 - Washer disinfectors

These 18 DIN trays capacity machines are the largest Steelco washer disinfector models designed to meet the increased reprocessing needs of CSSD.

These machines assure consistently tested and efficient washing-disinfecting performances.

DS 900 and DS 1000 models are available in standard or **Fast Cycle** versions.



All models can also be configured into a **narrow frame** to reduce their width to 900mm only.

Washing chamber

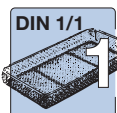

18X DIN 1/1 net basket capacity

Chamber vol. ~500 lt / ~132.09 Gal US
Wash cart vol. ~350 lt / ~92.46 Gal US

single door washer disinfectors

DS 900 Standard Cycle

DS 900 1S

DS 900 2S Fast Cycle

DS 900 3S

double door washer disinfectors

DS 1000 Standard Cycle

DS 1000 1S

DS 1000 2S Fast Cycle

DS 1000 3S

Washer dimensions

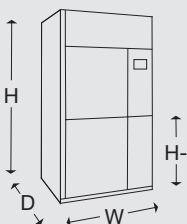

	W	D	H	H-
mm	1100	960	1940	850
inches	43.30	37.80	76.38	33.46

for both Standard Cycle and Fast Cycle versions - standard frame

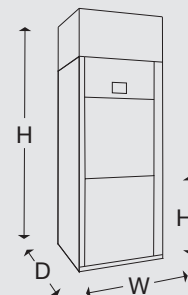
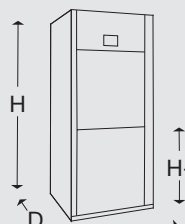

	W	D	H	H-
mm	900	960	1940	850
inches	35.43	37.80	76.38	33.46

Standard Cycle and Fast Cycle 1S version - narrow frame

	W	D	H	H-
mm	900	960	2620	850
inches	35.43	37.80	104.72	33.46

Fast Cycle 2S & 3S versions - narrow frame

DS 900 - DS 1000 - Key features

- Steelcronic control system supported by a color touch screen display.
- The ergonomic design of the door level height allows the user a convenient loading/unloading job.
- Vertical sliding down doors made of HST tempered glass.
- Inner cabinet, washing arms and tank filters made of high quality AISI 316L stainless steel. External cabinet made of AISI 304 stainless steel.
- Washing and DI disinfection temperature are fully adjustable up to 93°C/199°F.
- Temperature is monitored by two independent sensors.
- A powerful vertically installed washing pump ensures a high water flow rate combined with effective spray pressure and also grants a complete drain of the washing circuit.
- The triple water filtering system captures residue preventing re-circulation and extending the pump life.
- Washing/drying cart injection system.
- HEPA filtered H14 forced air drying system with adjustable time and temperature settings.
- Electrical heated 26kW total power (up to 40kW in Fast Cycle versions), 400V/3~+N/50Hz. Other electrical connections available as optional.
- Two standard automatic liquid dispensers provided with flow meter and level control.
- Possibility to store up to three 10 lt. (2.64 Gal US) containers into the basement (standard frame only).

Main optional features

- 3rd and 4th Chemical dosing pumps
- Steam or mixed heating
- Drain water heat exchanger
- Light inside of the chamber
- Conductivity sensor
- Steam condenser
- Drain cooling solenoid valve
- Integrated printer
- Analogic sensor on washing circuit for pressure check (registered data)
- Washing arm rotation sensors
- Bar code reader
- Turbo Drying (hot air recirculation system)
- Narrow frame (900 mm washer width)

Washing arms

Low friction bearings ease chamber and cart washing arms rotation for an improved efficiency of the washing and drying phases.

The spray arms are easily removable and the internal surface can be cleaned by hinged caps at the ends.

Washing cart automatic identification.

Triple water filtering system captures residue preventing re-circulation.



Active water coupling system

The connection system of the hydraulic circuit, between the washer and the washing cart, allows a tight seal junction for a more efficient cleaning and uniform disinfection temperature coverage.



Fast Cycle versions

total cycle time reduced up to **30 Minutes**

1S models are equipped with 1 big capacity pre-heating tank, **2S models** with 2, **3S models** with 3.

Functions and heating temperatures of the pre heating tanks can be configured to best suit the customer needs, allowing an effective results in reducing cycle time and water/energy recovery.

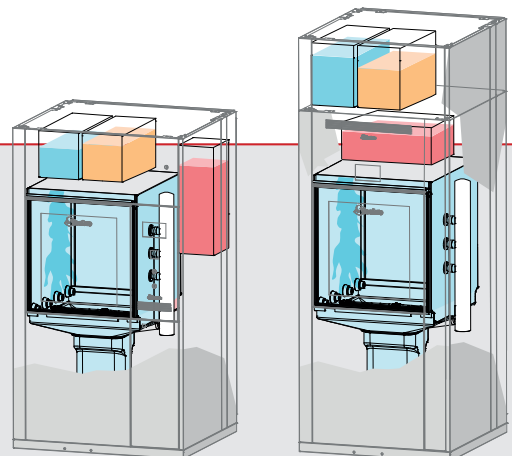



TW 3000/2 - "smart tunnel"

Double chamber compartment washer disinfector



width: 115 cm/45.27" only!

For the highest productivity

62 DIN 1/1 net trays per hour

The new **TW 3000/2** "Smart Tunnel" represents an innovative approach to high reprocessing capacity instrument washer disinfectors with a productivity of up to 62 DIN 1/1 net trays per hour.

With its simple and clever concept, this double chamber tunnel washer disinfector easily reaches the highest productivity/space and productivity/cost ratios in the market.

High throughput, low costs

By providing a higher throughput, the number of required devices is significantly reduced so that additional space is gained and investment costs can be lowered.

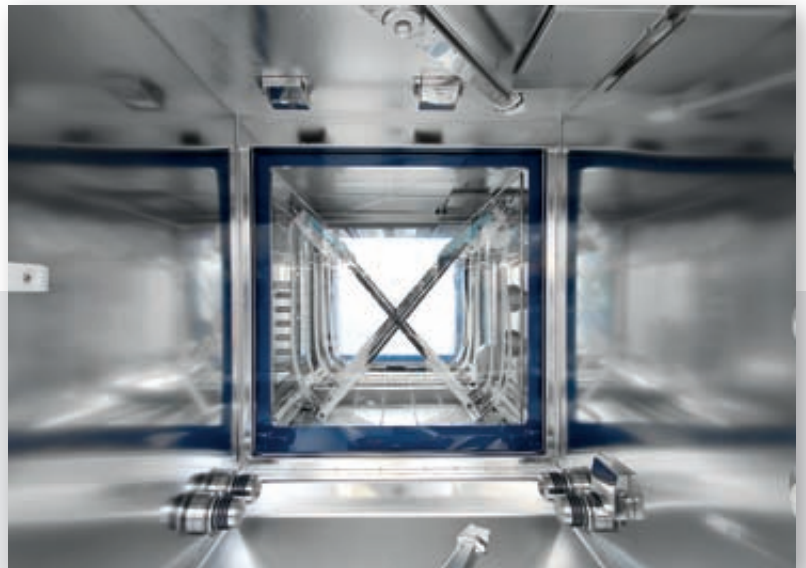

Washing chamber



Chamber vol. ~500 lt / ~132.09 Gal US
Wash cart vol. ~350 lt / ~92.46 Gal US

The new technique for automatic cleaning and disinfecting sets the standard for throughput, energy efficiency, low consumption and cost reduction

Cycle phases distribution across the two chambers

1st chamber

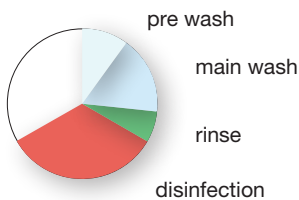

The first chamber is dedicated to the washing and disinfection phases and takes advantage of the most efficient pre heating tank configuration of Steelco CSSD **Fast Cycle** washer disinfectors.

A guarantee for efficient washing and disinfection performances and for the highest levels of energy and water savings.

2nd chamber



The second chamber is dedicated exclusively to the drying phase.

This allows dedicated vented ports to create the high turbulence air flow needed to reach the most efficient drying results.

Proper drying both inside and outside of the instruments is reached much faster reducing as a consequence energy and HEPA filter consumption.

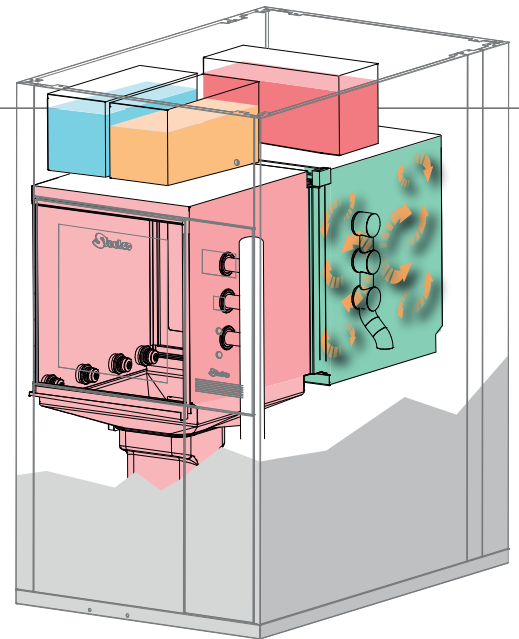

18 DIN 1/1 net basket output every 17 Minutes

Frontal maintenance access: the key to manage the restricted space challenge

When planning a new CSSD department, sufficient width of the room is essential to place the required number of devices for throughput according to each individual need.

In a limited width room, Steelco TW-3000/2 Smart Tunnel provides the most radical increase of productivity without the need of a larger lateral floor space than the one of a conventional single chamber washer.

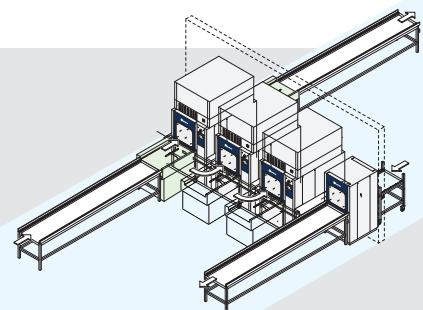



TW 3000/2 - Key features

- Steelcotronic control system supported by a color touch screen display.
- The ergonomic design of the door level height allows the user a convenient loading/unloading job.
- Automatic motorized vertical sliding up doors.
- Doors made of HST (High shock tested) tempered glass with safety device.
- Inner cabinet, washing arms and tank filters made of high quality AISI 316L stainless steel. External cabinet made of AISI 304 stainless steel.
- Washing and DI disinfection temperature are fully adjustable up to 93°C/199°F.
- Temperature is monitored by two independent sensors.
- A powerful vertically installed washing pump ensures a high water flow rate combined with effective spray pressure and also grants a complete drain of the washing circuit.
- The triple water filtering system captures residue preventing re-circulation and extending the pump life.
- Washing/drying cart injection system.
- HEPA filtered H14 forced air drying system with adjustable time and temperature settings.
- Washing cart automatic identification.
- Electrical heated with a total power of 63kW - 400V/3~+N/50Hz. Other electrical connections available as option.
- Two standard automatic liquid dispensers provided with flow meter and level control.

Main optional features

- 3rd and 4th Chemical dosing pumps
- Steam or mixed heating
- Drain water heat exchanger
- Light inside of the chambers
- Conductivity sensor
- Steam condenser
- Drain cooling solenoid valve
- Integrated printer
- Analogic sensor on washing circuit for pressure check (registered data)
- Washing arm rotation sensors
- Bar code reader

System integration

TW 3000/2 can be combined with ATS system and DS 1000 washer disinfectors.

It is organized to accept and manage the same range of carts and accessories used in DS 1000.

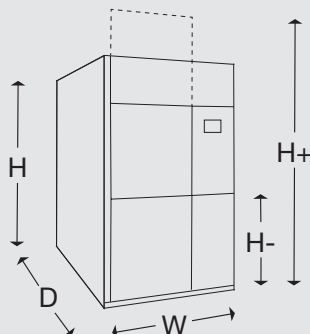

Washer dimensions

		W	D	H	H+	H-
TW 3000/2	mm	1150	1775	1980	2280	850
	inches	45.27	69.88	77.95	89.76	33.46

US 1000 - Ultrasonic cleaner



Steelco US 1000 has been designed to conveniently integrate surgical instruments ultrasonic treatment function into an automated CSSD reprocessing solution.

Steelco US 1000 can be connected to the automatic loading/unloading system of racks coming from a pre-wash machine and with destination to the ATS (automatic transfer system).

US 1000 is equipped with an automatic cart elevator

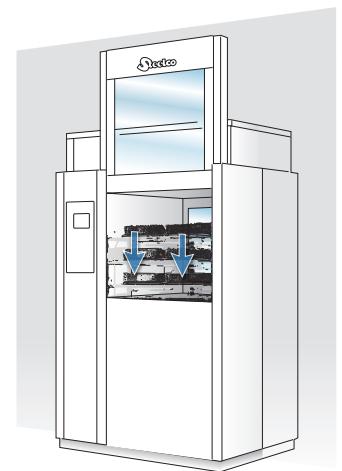

Main optional features

- Control of the ultrasonic system efficiency for the cycle validation
- 2nd chemical pump for disinfectant products
- Communication Software for supervision
- Light inside of the chamber
- Integrated system for the automatic chamber disinfection available in two versions:
 - **chemical disinfection** independent circuit for the chamber rinsing through an upper rotating arm connected to a disinfectant dispenser.
 - **steam disinfection** through the inlet of steam at 90°C / 194°F, hold for 60 seconds and checked by an independent temperature probe control.

Washing chamber

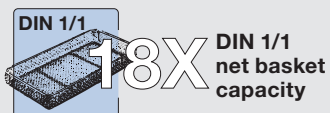

Chamber vol. ~500 lt / ~132.09 Gal US
Wash cart vol. ~350 lt / ~92.46 Gal US

Key features

- Washing chamber made of stainless steel AISI 316 L.
- Automatic HST glass sliding doors.
- Ultrasonic power 4000w – 38khz, with radio frequency interference filter and power control from 0 to 100% included.
- Automatic chemical dosing pump and flow meter for chemical validation. Minimum chemical level control with alarm.
- PLC microprocessor control with high storage capability for washing programs. The touch screen colour display interface allows a complete indication of machine function and residual cycle time highlight. Auto diagnosis function for an easy technical support.
- Ethernet connection.



TW 3000/3 /4 /5

Multi Chamber Compartment Washer Disinfector



TW 3000 is specially designed for those processing departments, **with a high rate of medical devices and utensils, installed in a restricted space.**

It improves staff productivity and efficiency, saves time and energy consumption.



Washing chamber



DIN 1/1 net basket capacity

Chamber vol. ~500 lt / ~132.09 Gal US
Wash cart vol. ~350 lt / ~92.46 Gal US

TW 3000/3 - /4 - /5

Fulfil the European EN ISO15883-1/2 requirements.



System integration

TW 3000 can be combined with ATS system and DS 1000 washer disinfectors.

It is organized to accept and manage the same range of carts and accessories used in DS 1000.

TW 3000/3 /4 /5 - Key features



Simple operation:

a scanner automatically reads the barcodes, selects the relevant washing program and runs through the different washing/drying chambers under Steelcotronic control.



Steelcotronic:

The machine is equipped with a PLC control unit with Colour Touch Screen display with 100 disinfection programs stored as standard.

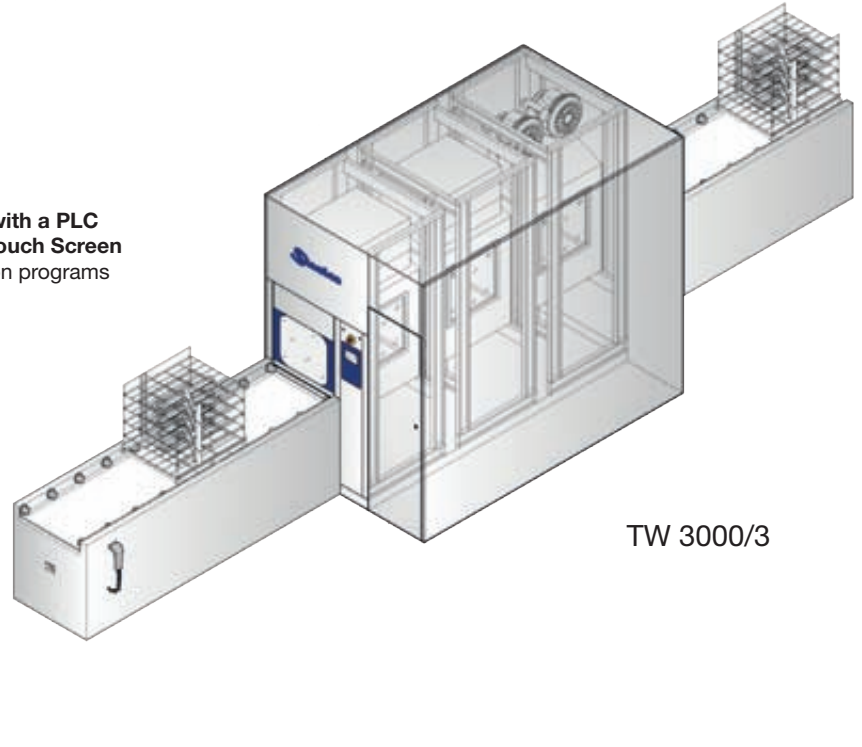

TW 3000/3

- Independent chambers improve throughput by processing multiple cycle simultaneously.
- Loading-unloading areas provided with fully automatic conveyors.
- CSSD clean side connected to soiled side by fully automatic return conveyors.
- Validation port at each chamber.

Applied solutions





TW 3000/3 /4 /5 - Multi Chamber Compartment Washer Disinfecter



Washing chamber

- Triple water stainless steel filtering system which captures residue preventing re-circulation and extending the pump life
- Extremely smooth chamber surface, welds without pockets and folds.
- 2 heavy stainless steel vertical installed washing pumps, into each washing/disinfection chamber, ensure high flow rate combined with effective spray pressure and also grant a complete drain of the washing circuit.
- HST glass sliding doors between each chamber prevent any carryover of contamination from the chambers.
- Cycle visual inspection, from service compartment, is possible at any time through HST glass windows.
- Chamber heat and noise insulated.

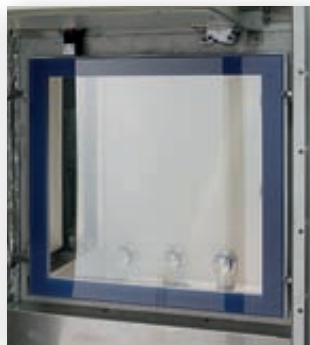

Heat recovery

- Cold DI water is preheated using water from the previous thermal disinfection phase (90°C [200°F]), thus reducing energy consumption.



Detergent dosing system

- The pumps are connected to the washing and disinfecting chambers. In case one chamber is down the detergent flow can be redirected to the other chamber ensuring a complete wash and thermal disinfection cycle in one chamber

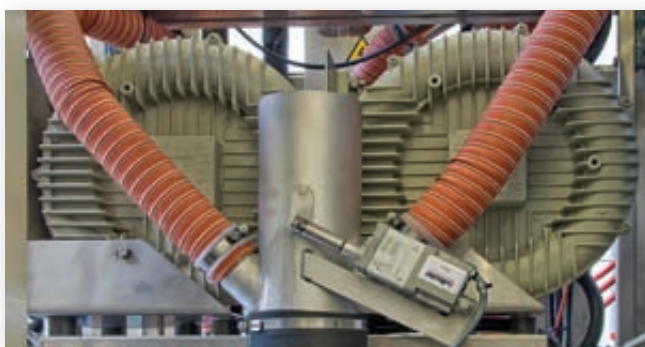

Drying and filtering

- The HEPA filtered forced turbo drying system equipped with 2 high performance fans, with hot air recirculation into the chamber through spray arms and air ducts, helps to ensure the complete inside and outside drying of all the surgical instruments and tubes and make the process fast while saving energy.



Tanks and connections

- Chambers equipped with pre-heated tanks and recirculation tank.
- Tank connection of external measuring sensors.



Service access and industrial quality electric panels

- Service access from one side grants easy access to all the machine components.

Modular flexibility

The system can be configured from 3 up to 5 chambers, depending on throughput requirements. On request, extra modules can be added after installation to adapt TW 3000 to new future needs.

3 washing stages example

- 1 Loading conveyor
- 2 Washing chamber
- 3 Disinfection chamber
- 4 Drying chamber
- 5 Unloading conveyor

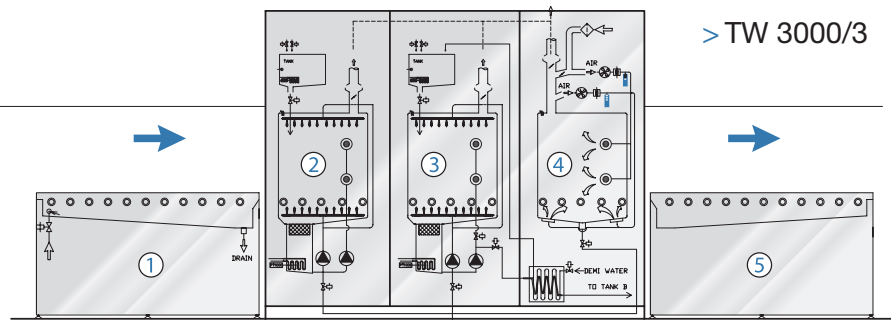

> TW 3000/3

4 washing stages example

- 1 Loading conveyor
- 2 Washing chamber
- 3 Ultrasonic chamber
- 4 Disinfection chamber
- 5 Drying chamber
- 6 Unloading conveyor

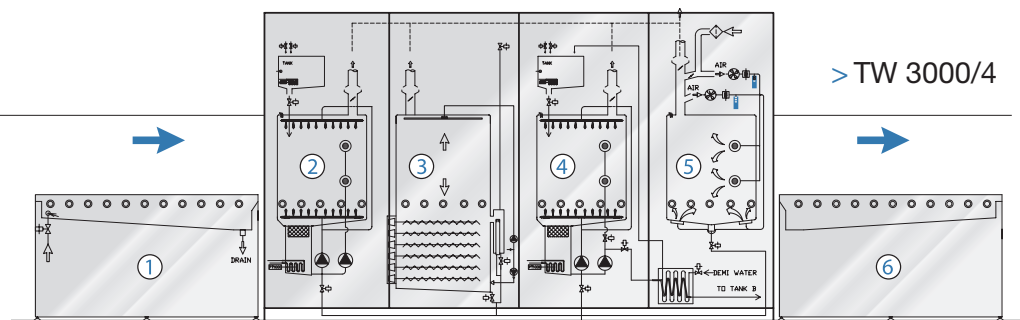

> TW 3000/4



Drying cabinets

Steelco drying cabinets are **available in several configurations:**

- full width shelves dedicated to instruments, equipment and general items, to mixed solutions for anaesthesia items and instruments.

Blanket warming version available as well.

Cabinets are available in single door or double door pass through versions with glass doors for a rapid visual inspection of the stored items.



ID 300

Instrument drying cabinet



- capacity up to nr. 18 DIN 1/1 trays on 9 removable shelves, supplied with nr. 8 shelves.



AD 400

Instrument, anaesthesia bags and hanging hoses mixed drying cabinet

Composition

- up to nr. 3 AN cassettes for a total capacity of 36 anaesthesia hoses
- up to nr. 9 DIN 1/1 trays capacity on 9 removable shelves
- or
- up to nr. 18 anaesthesia bags capacity
- up to nr. 9 DIN 1/1 trays capacity on 9 removable shelves

Supplied with nr. 8 shelves and nr. 3 AN cassettes.



BD 500

Blankets warming cabinet

- 4 removable shelves for blankets (standard). Shelves can be added and adjusted for different sizes of load.



standard

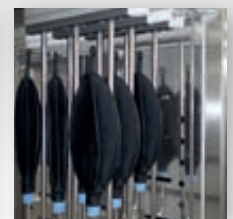

option

General key features

- Insulated double walled AISI 304 stainless steel construction that ensures the exterior surface temperature does not exceed 49°C (120°F). Temperature of tempered glass door does not exceed 49°C (120°F).
- Visual “open door” indicator. Lockable door.
- LED display, programmable for °C and °F, provides control and heater-on information for easy serviceability. Temperature and time settings are password protected to prevent unauthorized changes.
- Drying temperature settable from ambient to 80°C (176°F). Temperature alarms are disabled when door is open and for the time required to re-equilibrate temperatures in cabinet after door is closed. Temperature setting from 1 up to 999 min or continuous. Once the selected temperature is attained, it will be controlled throughout within 5.5°C (10°F) of the selected temperature. Overheat protection will shut the heater off with audible alarm for operator
- Indirect UV air treatment during the whole cycle. Optional.
- Drying circuit with double fan combined with fast connectors (optional).
- Flashing air flow visual alarm indicators if either drying circuit fails.
- Air flow alarm with re-settable audible alarm, (flashing alarm indication remains until the air flow is restored).
- HEPA filtration on drying circuit. Monitoring for HEPA filter and indicator on panel advising when replacement is required.
- Control components positioned in top front position for convenient service access. Easy removal of fans, heater elements and control boards.

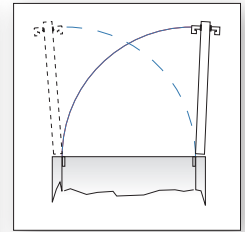
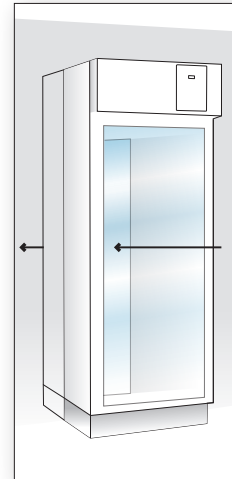

Lockable doors are reversible and configurable right or left opening also during installation.
Double door pass through version available.

Optional

- nr. 8 or 9 air fast connections
- extra shelves with rails
- UV air treatment
- Humidity sensor
- ST2 printer

Dimensions and connections

Std electrical conn. (International)
230V/~ /50Hz

Opt. electrical conn. (North America)*
220V/~ /60Hz

Power ID 300 - BD 500
1700 W

Power AD 400
1750 W

*other electrical connections also available as optional

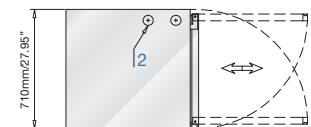
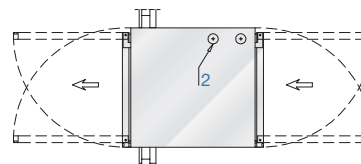
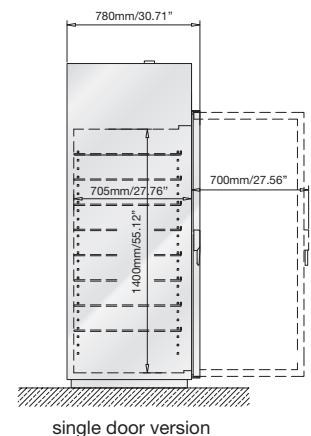
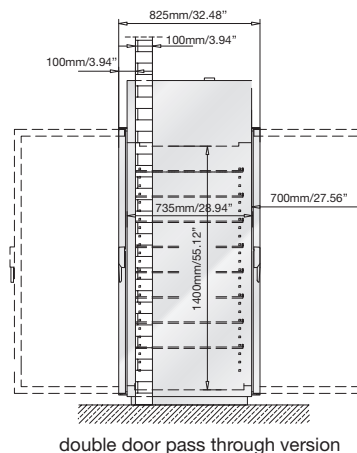
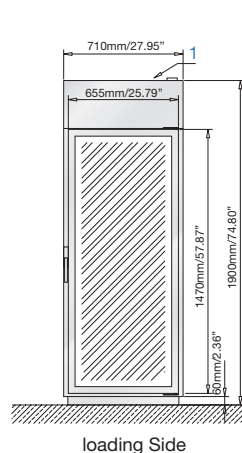

Separate drying of anesthesia and various special instrument accessories increases the throughput of a washer disinfector by a third. Drying cabinets can be loaded with the volume of up to two washer disinfectors.



www.steelcospa.com



Headquarters

STEELCO S.p.A.

Via Balegante, 27 - 31039 Riese Pio X (TV) - Italy
 Ph. +39 0423 7561 - Fax +39 0423 755528
 e-mail: steelco@steelcospa.com
www.steelcospa.com

Branches

STEELCO HUNGARY

Temesvár u., 19-21
 1116 Budapest - Hungary
 Ph. +36 1 371 0257
 Fax +36 1 371 0258
 e-mail: steelco@t-online.hu

STEELCO USA

7354 Central Industrial Drive
 West Palm Beach, FL 33404 USA
 Ph. +1 561 791 8313
 Fax +1 561 791 8213
 e-mail: steelco-usa@steelcospa.com

STEELCO ASIA

6th floor, Suite 16, IOI Business Park
 Persiaran Puchong Jaya Selatan - Bandar Puchong Jaya
 47100 Puchong, Selangor - Malaysia
 Ph +60 3 8064 4339 (Ext. 112) - Fax: +60 3 8064 4340
 e-mail: steelco-asia@steelcospa.com

